

Detachable Hinges With Spring

- Product Overview of Flat Hinges**
 Economy Series Detachable Hinges With Spring
 Feature of Flat Hinges: This product is a detachable hinge with spring, allowing for insertion and removal from both left side and right side.



- Product Features of Flat Hinges**
 Flat Hinges, The materials of this hinge include steel and stainless steel, which can be selected according to individual needs.
- Specifications Overview of Flat Hinges**

Type	M Material	S Surface Treatment
DE-HYGL	SPCC	Zinc Plating
DE-HYGR		
DE-HYSL	SUS304	Buffed
DE-HYSR		

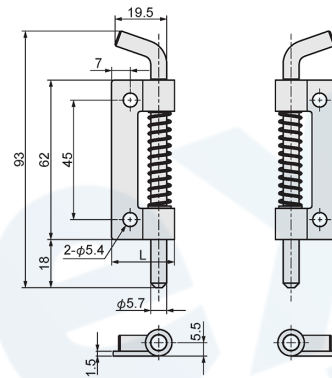

- Example Use of Flat Hinges**



Type	No.	Specification	L (mm)	Radial Load (N)	Axial Load (N)	Weight (g)
DE-HYGL	60	Left Pull-Out Type	23	100	130	43
DE-HYGR		Right Pull-Out Type				
DE-HYSL		Left Pull-Out Type	25	150	200	
DE-HYSR		Right Pull-Out Type				

Basic Specifications

- Length (mm)** - 89
- Width (W) (mm)** - 25.4
- Main Body Type** - Detachable Hinges
- Number of Holes** - 2
- Color** - Black

