

X-Axis Manual Stages, Linear Ball Guide

Dimensional Drawing of Manual X-Axis Stages

DE-XSG25

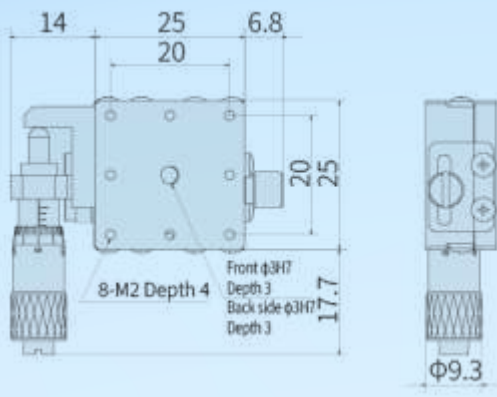

DE-XSG40

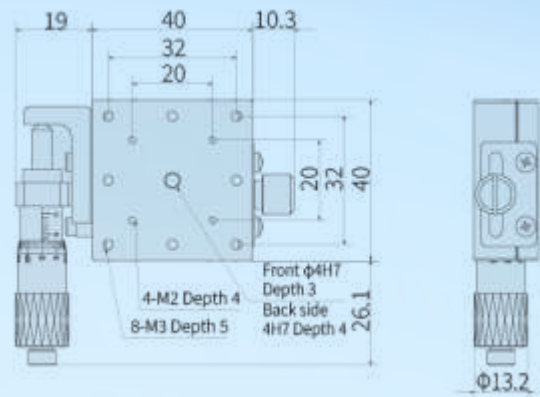

DE-XSG60

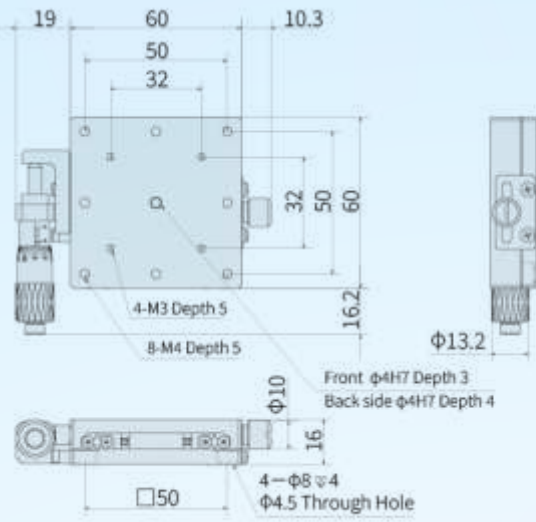

DE-XSG80

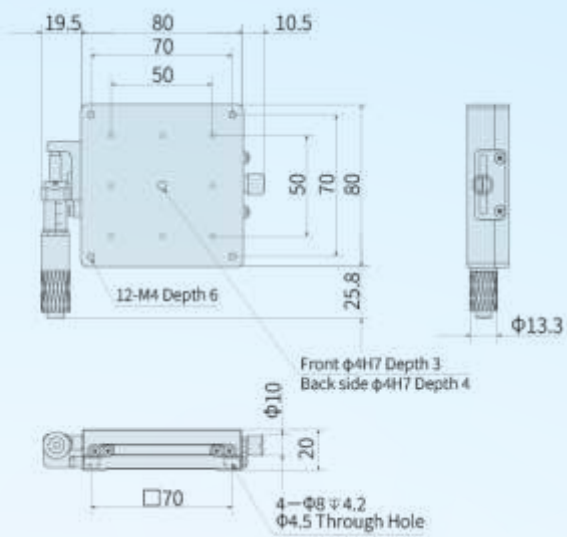

DE-XSG100

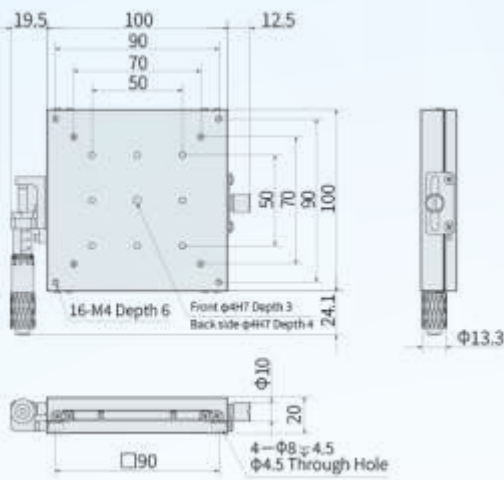

*A25, A40, A60, A80, A100 are available sizes of the screw hole on sliding table
Specification Table of Manual X-Axis Stages
Specification Table of Manual X-Axis Stages



Part Number of Manual X-Axis Stages		Manual X-Axis Stages (mm)	Movement (mm)	Load Capacity (N)	Straightness	Minimum Reading (μm)	Weight (kg)
Type of Manual X-Axis Stages	No.			Horizontal			
DE-XSG	25	25×25	±3.25	39.2	Within 10	10	0.07
	40	40×40	±6.5	98			0.23
	60	60×60		196			0.4
	80	80×80		264.6			0.9
	100	100×100	±12.5	343			1.33

Alteration of Manual X-Axis Stages

Alterations of Manual X-Axis Stages	Changing the position of the micrometer knob				
Manual X-Axis Stages Spec.	Manual X-Axis Stages Center 	Center Left and Right Reverse 	Center Up and Down Reverse 	Center Left and Right/Up and Down Reverse 	Side Left and Right Reverse
Manual X-Axis Stages Code	A	AR	AZ	AZR	CR
Alterations of Manual X-Axis Stages	Changing the position of the micrometer knob				
Manual X-Axis Stages Spec.	Side Up and Down Reverse 	Left and Right/Up and Down Reverse 	Disc Clamping 	Opposite Clamping 	Without Micrometer Knob
Manual X-Axis Stages Code	CZ	CZR	H	P	MN

Caution of Manual X-Axis Stages

- Stage usage environment of X-Axis Stages
Usage environment of X-Axis Stages: 10~50°C, 20~70%RH (non-condensing)
Recommended usage environment of X-Axis Stages: 22±5°C, 20~70%RH (non-condensing)
- Guide mechanism of X-Axis Stages
Since a cross roller guide is used as the guide mechanism, inject lubricant in a timely manner according to the usage conditions to prevent the life of the cross roller guide from being reduced and deteriorated due to lubricant reduction.
- Clamping mechanism of X-Axis Stages
①The clamping mechanism of the slide table is fixed by the frictional force generated by the fastening screw, so if the external force exceeds the frictional force of the clamping mechanism, the slide table will move. The user must take appropriate measures during use to prevent the table surface from moving.
②Holding force refers to the value of the force that prevents the slide table from moving in the clamped state. The maximum holding force varies depending on the tightening torque, so ensure sufficient safety factors when designing.
- A slide table with a micrometer knob mounted on the transport mechanism is generally called a standard type if it has a shape like the figure below. You can freely select by combining the installation space, installation posture, and operation method. However, there are some models where the installation position of the micrometer knob cannot be changed due to the product structure.
- There may be cases where the upper and lower tables are deformed due to differences in the flatness of the installation surface. Deformation of the table surface causes backlash, loosening due to failure to obtain the specified preload, and poor sliding due to excessive preload. Therefore, it is recommended to maintain the flatness of the installation surface at approximately 5 microns.

