

# Round Coil Springs :

## L Dimension Configurable O.D. Referenced Stainless Steel

### ● Compression Springs

Type	Allowable Deflection	Material
DFWR	F=Lx60%	SWP-A
DFWF	F=Lx50%	
DFWT	F=Lx40%	
DFUR	F=Lx60%	SUS304-WPB
DFUF	F=Lx50%	
DFUT	F=Lx40%	

### <How to Calculate Spring Constant>

$$\text{Spring Constant} = \frac{\text{Max. Load (N(kgf))}}{\text{Lx Allowable Deflection (\%)}}$$

D Tolerance Ø5~14 ±0.3  
 Ø5~27 ±0.4  
 L Tolerance ~ 50 ±1  
 51~100 ±2  
 101~250 ±4

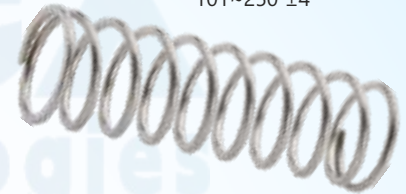
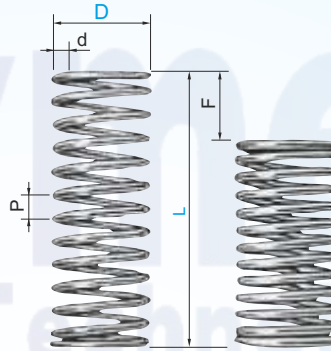

Use within the range of allowable deflection %.  
 No grinding on both ends for d less than 0.9.  
 P is for reference only.  
 Load types A and B have a different number of coils,  
 so the P dimension is different.

Part Number		1mm Increment L	Load Type Selection	Max. Load N(kgf)						d			P (Reference)			
Type	D			SWP-A			SUS304-WPB			DFWR DFUR	DFWF DFUF	DFWT DFUT	DFWR DFUR	DFWF DFUF	DFWT DFUT	
				DFWR60%	DFWF50%	DFWT40%	DFUR60%	DFUF50%	DFUT40%							
DFWR DFWF DFWT (SWP-A)	5	15~65	A	2.8(0.29)	5.2(0.53)	8.1(0.83)	2.5(0.25)	4.5(0.46)	7.1(0.73)	0.4	0.5	0.6	1.8	1.5	1.3	
			B	3.7(0.38)	6.7(0.69)	10.6(1.08)	3.3(0.33)	5.9(0.60)	9.3(0.95)							
	6	15~80	A	2.9(0.30)	7.3(0.75)	9.9(1.01)	2.5(0.26)	6.4(0.65)	8.7(0.89)	0.45	0.6	0.7	2.0	1.7	1.5	
			B	3.8(0.38)	9.6(0.97)	12.9(1.32)	3.3(0.34)	8.4(0.85)	11.3(1.15)							
	7	15~90	A	3.1(0.32)	10.1(1.03)	11.5(1.17)	2.7(0.28)	8.8(0.90)	10.0(1.02)	0.5	0.7	0.8	2.2	2.0	1.7	
			B	4.0(0.41)	13.1(1.34)	14.9(1.52)	3.5(0.36)	11.5(1.17)	13.0(1.33)							
	8	20~100	A	5.2(0.53)	12.2(1.24)	13.8(1.41)	4.6(0.47)	10.7(1.09)	12.1(1.23)	0.6	0.8	0.9	2.7	2.2	1.9	
			B	6.8(0.70)	15.9(1.62)	17.9(1.83)	6.0(0.61)	13.9(1.42)	15.7(1.60)							
	9	19~110	A	8.1(0.83)	17.4(1.78)	22.1(2.25)	7.1(0.72)	15.2(1.56)	19.3(1.97)	0.7	0.9	1.0	2.9	2.5	2.6	
			B	10.0(1.02)	20.6(2.09)	27.5(2.80)	8.7(0.89)	17.9(1.83)	24.0(2.45)							
	10	20~120	A	10.6(1.08)	19.2(1.96)	30.5(3.11)	9.3(0.95)	16.9(1.72)	26.7(2.72)	0.8	1.0	1.2	3.4	2.8	2.5	
			B	13.7(1.40)	24.9(2.54)	39.5(4.03)	12.1(1.23)	21.8(2.22)	34.6(3.53)							
11	21~130	A	9.0(0.92)	17.2(1.75)	27.9(2.85)	7.9(0.80)	15.0(1.53)	24.4(2.49)	0.8	1.0	1.2	3.5	3.3	2.9		
		B	12.6(1.28)	22.9(2.33)	36.3(3.70)	11.0(1.12)	20.0(2.04)	31.7(3.24)								
12	25~140	A	11.0(1.12)	27.6(2.81)	37.7(3.84)	9.6(0.98)	24.1(2.46)	33.0(3.34)	0.9	1.2	1.4	3.8	3.3	2.9		
		B	14.2(1.45)	35.8(3.65)	48.9(4.99)	12.5(1.27)	31.3(3.19)	42.9(4.37)								
13	24~150	A	10.5(1.07)	26.5(2.70)	35.7(3.63)	9.1(0.93)	23.2(2.37)	31.1(3.18)	0.9	1.2	1.4	4.2	3.9	3.3		
		B	13.4(1.37)	34.6(3.52)	46.4(4.73)	11.7(1.20)	30.2(3.08)	40.5(4.13)								
14	30~160	A	11.6(1.18)	37.7(3.84)	45.9(4.68)	10.1(1.03)	33.0(3.36)	40.2(4.10)	1.0	1.4	1.6	4.2	3.9	3.3		
		B	15.1(1.54)	48.9(4.99)	59.6(6.08)	13.1(1.34)	42.8(4.36)	52.2(5.32)								
15	27~170	A	11.4(1.16)	36.8(3.75)	44.4(4.53)	9.9(1.01)	32.1(3.28)	38.8(3.96)	1.0	1.4	1.6	5.0	4.5	3.7		
		B	14.9(1.51)	47.1(4.80)	56.6(5.77)	14.9(1.33)	41.1(4.20)	49.4(5.05)								
16	30~180	A	19.4(1.98)	49.7(5.07)	55.1(5.62)	17.0(1.73)	43.4(4.43)	48.2(4.91)	1.2	1.6	1.8	5.0	4.5	3.7		
		B	25.1(2.56)	64.5(6.58)	71.2(7.26)	22.0(2.24)	56.5(5.76)	62.6(6.38)								
17	31~190	A	19.6(2.00)	47.9(4.88)	53.5(5.45)	17.1(1.75)	41.8(4.27)	46.7(4.77)	1.2	1.6	1.8	5.9	5.0	4.1		
		B	25.3(2.57)	62.0(6.32)	69.9(7.13)	22.0(2.25)	54.1(5.53)	61.0(6.24)								
18	35~200	A	29.9(3.05)	62.1(6.33)	65.2(6.65)	26.2(2.67)	54.3(5.54)	57.1(5.82)	1.4	1.8	2.0	5.9	5.0	4.1		
		B	38.9(3.97)	80.7(8.23)	84.6(8.63)	34.0(3.47)	70.6(7.2)	74.0(7.55)								
20	40~200	A	42.7(4.35)	76.9(7.84)	99.0(10.1)	37.4(3.81)	67.3(6.86)	86.6(8.83)	1.6	2.0	2.3	6.7	5.5	4.8		
		B	55.2(5.63)	100(10.2)	128(13.1)	48.3(4.93)	87.2(8.89)	113(11.5)								
23	45~200	A	51.9(5.29)	103.0(10.50)	121.0(12.34)	45.4(4.63)	90.2(9.20)	106.0(10.81)	1.8	2.3	2.6	7.8	6.4	5.5		
		B	67.4(6.87)	133.0(13.56)	156.0(15.91)	58.9(6.01)	133.9(13.68)	137.0(13.97)								
25	50~250	A	64.5(6.58)	153.5(15.64)	178.6(18.20)	56.3(5.75)	113.0(11.52)	155.9(15.93)	2.0	2.6	2.9	10.2	8.0	7.9		
		B	82.4(8.39)	172.0(17.53)	214.3(21.84)	71.9(7.34)	150.1(15.34)	187.0(19.11)								
27	70~250	A	86.0(8.77)	195.0(19.87)	220.3(22.45)	75.0(7.67)	170.2(17.39)	192.3(19.64)	2.3	2.9	3.2	7.5	7.4	6.7		
		B	110.9(11.30)	214.2(21.83)	274.0(27.92)	96.8(9.89)	187.0(19.10)	239.1(24.43)								

Load (kgf) = Load N x 0.101972

### ORDERING GUIDE

