

Tamper Proof Button Head Cap Screws - Single Item / Small Box



Basic Specifications

- **Drive Type** - Hex Socket (Dedicated Tools)
- **Thread Type** - Metric, Coarse
- **Metric, Coarse** - Standard / For Vacuum Equipment
- **Detailed Shape** - Button Head Cap
- **Tip Shape** - Tip Shape
- **Screw Type** - Fully Threaded
- **Surface Treatment** - Not Provided
- **Additional Shape** - Standard

Tamper Proof Button Head Cap Screws

DIBNP

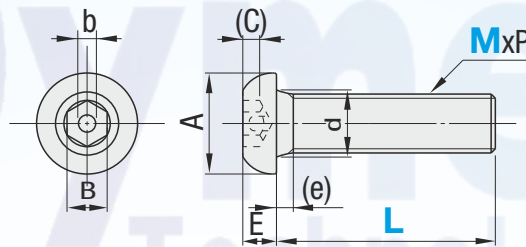

● Protruding pin in the socket is 0 ~ 0.5mm below the top of screw head.

M Material: SUS304 Equivalent

MxP (Coarse)	A	E	B	(C) (Min.)	d (Max.)	(e) (Max.)
3x0.5	5.7	1.65	2	1.0	1.04	3.6
4x0.7	7.6	2.2	2.5	1.1	1.3	4.7
5x0.8	9.5	2.75	3	1.3	1.56	5.7
6x1.0	10.5	3.3	4	1.6	2.08	6.8
8x1.25	14	4.4	5	2	2.6	9.2

Part Number Type	M - L
DIBNP	3 - 6
	8
	10
	12
	16
	4 - 8
	10
	12
	16
	20
	25
	30
	5 - 10
	12
	16
	20
25	
30	
40	

Part Number Type	M - L
DIBNP	6 - 10
	12
	16
	20
	25
	30
	40
	50
	8 - 10
	12
	16
	20
	25
	30
	35
	40
45	
50	

Dedicated Wrenches DIBKPL

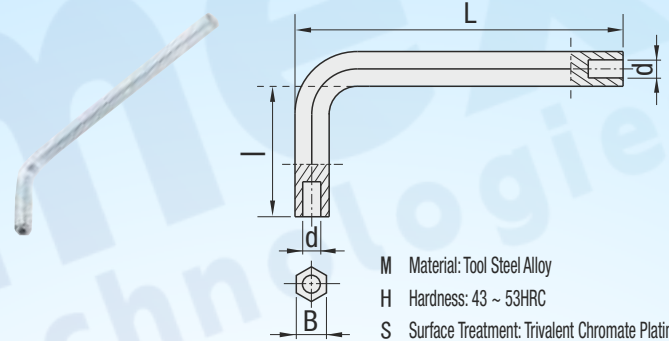

M Material: Tool Steel Alloy
H Hardness: 43 ~ 53HRC
S Surface Treatment: Trivalent Chromate Plating

Part Number Type	No.	Applicable Screw	L	l	d	B
DIBKPL	3	M3	52	16	1.2	2
	4	M4	58.5	20.5	1.3	2.5
	5	M5	66	23	1.5	3
	6	M6	74	29	1.8	4
	8	M8	85	33	2.3	5

ORDERING GUIDE



DIBNP6-20
DIBKPL3

www.dymextech.com
india@dymextech.com