

Coil Springs – HIGH DEFLECTION DSWR

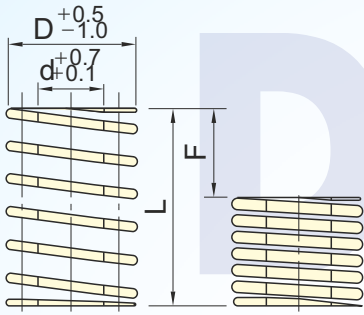

Load $\pm 10\%$
 Squareness 3° or less
 Free length L 50 or less $\pm 0.5\text{mm}$
 55 or more $\pm 1.5\%$

M~SWP~A

Coil direction Right: Sectional drawing

For information on the D dimension and the counterbore hole, and also the d dimension and the shaft

● F(Allowable deflection) is due to the measurement at normal temperature (40°C)

Maximum allowable deflection at high temperature ($150^\circ/200^\circ\text{C}$).

Part No. Type D-L	D	d	L	Spring Constant		F = L x 50%	
				N/mm(kgf/mm)	Fmm	Load N(kgf)	Load N(kgf)
DSWR10.5 - 15	10.5	5.5	15	10.46 (1.07)	7.5	78.5 (8.0)	
			20	7.85 (0.80)	10.0		
			25	6.28 (0.64)	12.5		
			30	5.23 (0.53)	15.0		
			35	4.48 (0.46)	17.5		
			40	3.92 (0.40)	20.0		
			45	3.49 (0.36)	22.5		
			50	3.14 (0.32)	25.0		
			55	2.85 (0.29)	27.5		
			60	2.62 (0.27)	30.0		
			65	2.41 (0.25)	32.5		
DSWR12.5 - 15	12.5	7.0	15	11.77 (1.20)	7.5	88.3 (9.0)	
			20	8.83 (0.90)	10.0		
			25	7.06 (0.72)	12.5		
			30	5.88 (0.60)	15.0		
			35	5.04 (0.51)	17.5		
			40	4.41 (0.45)	20.0		
			45	3.92 (0.40)	22.5		
			50	3.53 (0.36)	25.0		
			55	3.21 (0.33)	27.5		
			60	2.94 (0.30)	30.0		
			65	2.72 (0.28)	32.5		
DSWR14.5 - 15	14.5	8.5	15	17.00 (1.73)	7.5	127.5 (13)	
			20	12.75 (1.30)	10.0		
			25	10.20 (1.04)	12.5		
			30	8.50 (0.87)	15.0		
			35	7.28 (0.74)	17.5		
			40	6.37 (0.65)	20.0		
			45	5.67 (0.58)	22.5		
			50	5.10 (0.52)	25.0		
			55	4.64 (0.47)	27.5		
			60	4.25 (0.43)	30.0		
			65	3.92 (0.40)	32.5		

Part No. Type D-L	D	d	L	Spring Constant		F = L x 50%	
				N/mm(kgf/mm)	Fmm	Load N(kgf)	Load N(kgf)
DSWR17 - 20	17	10.5	20	19.61 (2.00)	10.0	196.1 (20.0)	
			25	15.69 (1.60)	12.5		
			30	13.08 (1.33)	15.0		
			35	11.21 (1.14)	17.5		
			40	9.81 (1.00)	20.0		
			45	8.72 (0.89)	22.5		
			50	7.85 (0.80)	25.0		
			55	7.13 (0.73)	27.5		
			60	6.54 (0.67)	30.0		
			65	6.03 (0.62)	32.5		
			70	5.60 (0.57)	35.0		
DSWR21 - 150	21	13.5	150	2.62 (0.27)	75.0	294.2 (30.0)	
			175	2.24 (0.23)	87.5		
			25	23.54 (2.40)	12.5		
			30	19.61 (2.00)	15.0		
			35	16.81 (1.71)	17.5		
			40	14.71 (1.50)	20.0		
			45	13.08 (1.33)	22.5		
			50	11.77 (1.20)	25.0		
			55	10.70 (1.09)	27.5		
			60	9.81 (1.00)	30.0		
			65	9.05 (0.92)	32.5		
DSWR26 - 150	26	16.5	150	3.92 (0.40)	75.0	392.3 (40.0)	
			175	3.36 (0.34)	87.5		
			200	2.94 (0.30)	100.0		
			25	31.38 (3.20)	12.5		
			30	26.15 (2.67)	15.0		
			35	22.42 (2.29)	17.5		
			40	19.61 (2.00)	20.0		
			45	17.43 (1.78)	22.5		
			50	15.69 (1.60)	25.0		
			55	14.26 (1.45)	27.5		
			60	13.08 (1.33)	30.0		

M Equivalent of SWOSC – V (Steel Wire Oil Temper Silicon for Valve)

● Load calculation method: Load = Spring constant x Deflection
 (International unit) $N = N/mm \times Fmm$
 $kgf = kgf/mm \times Fmm$
 $(kgf = N \times 0.101972)$



Coil Springs – HIGH DEFLECTION DSWR

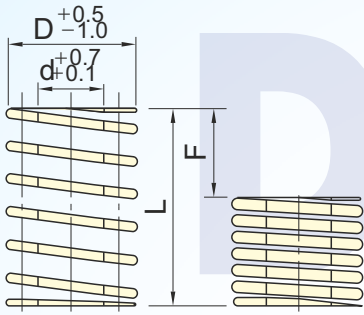

Load $\pm 10\%$
 Squareness 3° or less
 Free length L 50 or less $\pm 0.5\text{mm}$
 55 or more $\pm 1.5\%$

M~SWP~A

Coil direction Right: Sectional drawing

For information on the D dimension and the counterbore hole, and also the d dimension and the shaft

● **F(Allowable deflection) is due to the measurement at normal temperature (40°C)**
 Maximum allowable deflection at high temperature (150°/200°C).

Part No. Type D-L	D	d	L	Spring Constant		F = L x 50%	
				N/mm(kgf/mm)	Fmm	Load N(kgf)	
DSWR31 - 35	31	21	35	28.02 (2.86)	17.5	490.3 (50.0)	
40			24.52 (2.50)	20.0			
45			21.79 (2.22)	22.5			
50			19.61 (2.00)	25.0			
55			17.83 (1.82)	27.5			
60			16.34 (1.67)	30.0			
65			15.09 (1.54)	32.5			
70			14.01 (1.43)	35.0			
75			13.08 (1.33)	37.5			
80			12.26 (1.25)	40.0			
90			10.90 (1.11)	45.0			
100			9.81 (1.00)	50.0			
110			8.92 (0.91)	55.0			
120			8.17 (0.83)	60.0			
125			7.85 (0.80)	62.5			
130			7.54 (0.77)	65.0			
140			7.00 (0.71)	70.0			
150			6.54 (0.67)	75.0			
160			6.13 (0.63)	80.0			
170			5.77 (0.59)	85.0			
175	5.60 (0.57)	87.5					
180	5.45 (0.56)	90.0					
190	5.16 (0.53)	95.0					
200	4.90 (0.50)	100.0					
250	3.92 (0.40)	125.0					
300	3.27 (0.33)	150.0					
DSWR37 - 35	37	26	35	33.62 (3.43)	17.5	588.4 (60.0)	
40			29.42 (3.00)	20.0			
45			26.15 (2.67)	22.5			
50			23.54 (2.40)	25.0			
55			21.40 (2.18)	27.5			
60			19.61 (2.00)	30.0			
65			18.10 (1.85)	32.5			
70			16.81 (1.71)	35.0			
75			15.69 (1.60)	37.5			
80			14.71 (1.50)	40.0			
90			13.08 (1.33)	45.0			
100			11.77 (1.20)	50.0			
110			10.70 (1.09)	55.0			
120			9.81 (1.00)	60.0			
125			9.41 (0.96)	62.5			
130			9.05 (0.92)	65.0			
140			8.41 (0.86)	70.0			
150			7.85 (0.80)	75.0			
160			7.35 (0.75)	80.0			
170			6.92 (0.71)	85.0			
175	6.72 (0.69)	87.5					
180	6.54 (0.67)	90.0					
190	6.19 (0.63)	95.0					
200	5.88 (0.60)	100.0					
250	4.71 (0.48)	125.0					
300	3.92 (0.40)	150.0					

Part No. Type D-L	D	d	L	Spring Constant		F = L x 50%	
				N/mm(kgf/mm)	Fmm	Load N(kgf)	
DSWR44.5-	43	31	50	33.34 (3.40)	25.0	833.6 (85)	
60			27.79 (2.83)	30.0			
70			23.82 (2.43)	35.0			
80			20.84 (2.13)	40.0			
90			18.52 (1.89)	45.0			
100			16.67 (1.70)	50.0			
110			15.16 (1.55)	55.0			
120			13.89 (1.42)	60.0			
130			12.82 (1.31)	65.0			
140			11.91 (1.21)	70.0			
150			11.11 (1.13)	75.0			
160			10.42 (1.06)	80.0			
170			9.81 (1.00)	85.0			
180			9.26 (0.94)	90.0			
190			8.77 (0.89)	95.0			
200			8.34 (0.85)	100.0			
225			7.41 (0.76)	112.5			
250			6.67 (0.68)	125.0			
275			6.06 (0.62)	137.5			
300			5.56 (0.57)	150.0			
DSWR46 -	46	33	50	43.15 (4.40)	25.0	1079 (110)	
60			35.96 (3.67)	30.0			
70			30.82 (3.14)	35.0			
80			26.97 (2.75)	40.0			
90			23.97 (2.44)	45.0			
100			21.57 (2.20)	50.0			
110			19.61 (2.00)	55.0			
120			17.98 (1.83)	60.0			
125			17.26 (1.76)	62.5			
130			16.60 (1.69)	65.0			
140			15.41 (1.57)	70.0			
150			14.38 (1.47)	75.0			
175			12.33 (1.26)	87.5			
200			10.79 (1.10)	100.0			
225			9.59 (0.98)	112.5			
250	8.63 (0.88)	125.0					
275	7.85 (0.80)	137.5					
300	7.19 (0.73)	150.0					
DSWR52 -	50	36	50	52.96 (5.40)	25.0	1324 (135)	
60			44.13 (4.50)	30.0			
70			37.83 (3.86)	35.0			
80			33.10 (3.38)	40.0			
90			29.42 (3.00)	45.0			
100			26.48 (2.70)	50.0			
110			24.07 (2.45)	55.0			
120			22.06 (2.25)	60.0			
130			20.37 (2.08)	65.0			
140			18.91 (1.93)	70.0			
150			17.65 (1.80)	75.0			
175			15.13 (1.54)	87.5			
200			13.24 (1.35)	100.0			
225			11.77 (1.20)	112.5			
250			10.59 (1.08)	125.0			
275	9.63 (0.98)	137.5					
300	8.83 (0.90)	150.0					
350	7.57 (0.77)	175.0					
400	6.62 (0.68)	200.0					

Alteration	Code	Spec.
No painting	NT	Paint peeling Peel the coating by shot peening. ● Since the springs which have undergone the painting peeling are easy to rust, be careful in handling. A rusted spring could cause early breakage. ● Compared to painted springs, there may be some dispersions in terms of load, etc. depending on the lot.

