

# Shock Absorbers

## Adjustable

### DMAC (Cap)

### DMAS (No Cap)

( No.0806\*, 1008\*, 1210\*, 1214, 1410, 1417  
1612\*, 1620\*, 2016\*, 2530\*, 2725\*, 3035\*, 3650\* )  
Shapes of adjustable parts of \* marked products are as shown in figures below.

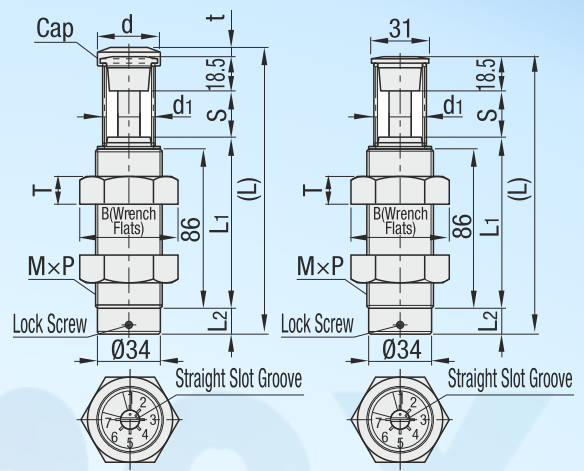
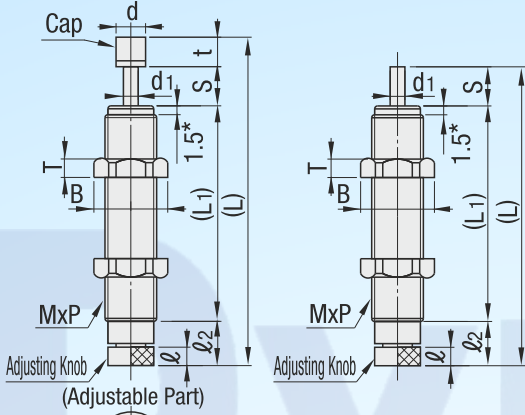

( No.1612, 1620, 2016 Shape of Adjustable Part  
2725, 3035, 3650 ) ( No.0806, 1008, 1210  
Shape of Adjustable Part ) (No.2530 Shape of Adjustable Part)

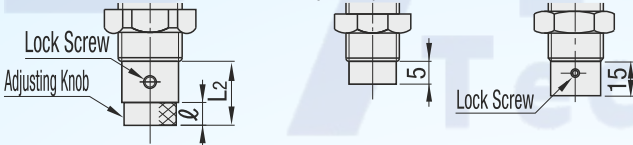

No.	M	Material (Main Body)	S	Surface Treatment
0806		SUS303		-
1008, 1210, 1214, 1410 1417, 1612, 1620, 3625		SUM		Electroless Nickel Plating
2016, 2530, 2725 3035, 3650		STKM12C		
Cap		Polyacetal 3035, 3625 and 3650 is urethane rubber		

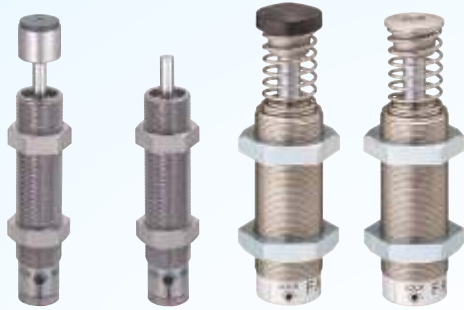

- Avoid parallel use of Adjustable Type as synchronization of shock absorption characteristics is difficult
- Impact force can be easily adjusted by turning the adjusting knob on the bottom.
- Operating Ambient Temperature: -5 ~ 70°C
- 1.5\* is the dimension of thread dia. M14 or smaller  
(except M8). M8 is 2.3, and M16 or larger is fully threaded
- Replace after 1,000,000 cycles

Part Number	Thread Dia MxP	Stroke S	Max. Absorbed Energy (E)		Max. Equivalent Mass (me') (kg)	Piston Rod Return Force (N)	Max. Drag Value (N)	(L)	(L1)	L2	l	d	d1	t	B (Wrench Flats)	T			
			per Impact (J)	per Minute (J)															
DMAC (Cap)	0806	M8 x 0.75	6	1.4	36.7	15	9 or Less	670	58 (53)	41	6	3	6	2.5	5	12.7 (11)	2		
	1008	S	M10 x 1.0	8	1.02	58.8	10	5.88 or Less	637	65.2 (58.9)	42.2	8.7	3.5	6	2.4	6.3	14.2 (13)	3	
		L			1.47														2.5
		M			1.76														100
		H			2.94														30
	1210	S	M12 x 1.0	10	2.94	98	30	9.8 or Less	1470	84 (76)	61	5	-	8	-	16.2 (14)	4		
		L			4.9													4	
		M			5.4													30	
	1214	H	M12 x 1.0	14	5.4		30	12.7 or Less	1156	92 (84)	59.5	10.5	5	3.5	8				
	1410	S	M14 x 1.5	10	3.62	147	30	9.8 or Less	1813	88 (80)	59	11	6	10	-	19.6 (17)	6		
		L			3.92													35	
		M			5.88													4.5	
		H			14.7													50	
	1417	H	M14 x 1.5	17	14.7	176	50	15.7 or Less	2646	115 (105)	77.8	10.2	5	4	10				
	1612	S	M16 x 1.5	12	6.3	235	50	14.7 or Less	2646	117 (102)	75.5	14.5	4.5	13.5	5	15	20 (19)	6	
		L			9.8														10
M		17.6			60														
H		20			60														
1620	H	M16 x 1.5	20	17.6		60	19.6 or Less	2646	143 (128)	93.5									
2016	S	M20 x 1.5	16	20	343	300	18.1 or Less	3528	127 (110)	76	18	4	18	6	17	27.7 (24)	8		
	L			29.4														200	
	M			23														120	
	H			23														1100	
2530	S	M20 x 1.5	30	23	490	400	33.2 or Less	3920	173 (155)	110	15	-	22	18	-	37 (32)	10		
	L			49														300	
	M			32														1500	
2725	H	M20 x 1.5	25	79.3	539	300	27.3 or Less	6370	156 (136)	91	20	5	23	20					
3035	S	M30 x 1.5	35	100	1176	1300	44.1 or Less	16660	206.5 (188)	128	25	-	27	10	18.5	41.6 M (36)	14		
	L			196														700	
	M			125														3500	
3625	S	M36 x 1.5	25	125	1500	2000	100 or Less	25000	155 (150)	92.5	14	-	34	12	5	53.1 (46)	10		
	L			200														700	
	M			235														6700	
3650	H	M36 x 1.5	50	392	2352	2700	68.6 or Less	23520	254.5 (235)	160	25	5	33	12	5		15		

■ L Dimension values in ( ) are for MAS.

kgf • m = Jx0.101972 kgf = Nx0.101972

Collision Velocity Type	Collision Velocity Type	Max. Operating Cycle
Ultra Low Speed S	0.08~0.5m/s	60cycle/min*
Low Speed L	0.3 ~1 m/s	
Medium Speed M	0.3 ~2 m/s	
High Speed H	0.7 ~3 m/s	

#### Basic Specifications

- Structure - Adjustable
- Operating Temperature Range (°C) - -5::70
- Main Body, Related Components - Main Body
- Operating Environment - Standard

■ \* No.0806 is 45cycle/min; No.3035, 3625 and 3650 are 30cycle/min.

ORDERING GUIDE



Part Number  
DMAC1008H

www.dymex.com  
india@dymex.com