

C-Shaped Retaining Ring (for Shaft) DSTW

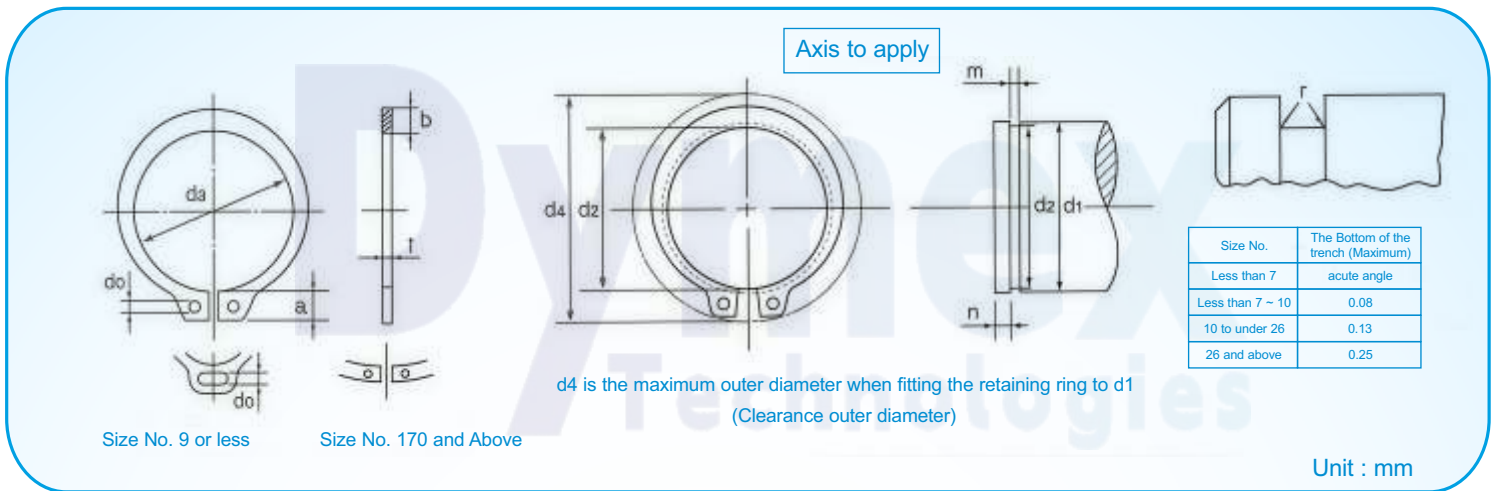

Size No.	Retaining Ring							d4 (Reference)	Applicable Hole					Reference n
	d3		t		b	a	d0		d1	d2		m		
	Basic Dimensions	Tolerance	Basic Dimensions	Tolerance	About	About	Smallest			Basic Dimensions	Tolerance	Basic Dimensions	Tolerance	
DSTW- ※3	2.7	+0.04	0.25	±0.025	0.5	1.7	0.7	7	3	2.85		0.35		0.3
※4	3.7	-0.15	0.4	±0.03	0.9	2.2	0.8	9	4	3.8	0	0.5		0.3
※5	4.7		0.6		1.1	2.4	0.8	10.5	5	4.8	-0.04	0.7	+0.1	0.3
※6	5.6		0.7	±0.04	1.3	2.8	1	12	6	5.7		0.8	0	0.5
※7	6.5	+0.06	0.8		1.4	3	1	14	7	6.7	0	0.9		0.5
※8	7.4	-0.2	0.8		1.6	3	1	15	8	7.6	-0.06	0.9		0.6
※9	8.4		1		1.8	3.2	1	16	9	8.6		1.15		0.6
※10	9.3	±0.15	1		1.8	3	1.2	17	10	9.6	-0.09	1.15		1.5
※11	10.2		1		2	3.1	1.2	18	11	10.5		1.15		1.5
※12	11.1		1		2.1	3.2	1.5	19	12	11.5		1.15		1.5
※13	12		1	±0.05	2.1	3.3	1.5	20	13	12.4		1.15		1.5
※14	12.9		1		2.2	3.4	1.7	22	14	13.4	0	1.15		1.5
※15	13.8	±0.18	1		2.2	3.5	1.7	23	15	14.3	-0.11	1.15		1.5
16	14.7		1		2.2	3.6	1.7	24	16	15.2		1.15		1.5
17	15.7		1		2.2	3.7	1.7	25	17	16.2		1.15		1.5
18	16.5		1.2		2.6	3.8	1.7	26	18	17		1.35		1.5
19	17.5		1.2		2.7	3.8	2	27	19	18		1.35		1.5
20	18.5		1.2		2.7	3.9	2	28	20	19		1.35		1.5
21	19.5		1.2		2.7	4	2	30	21	20		1.35		1.5
22	20.5		1.2		2.7	4.1	2	31	22	21		1.35		1.5
※23	21.4		1.2		2.9	4.5	2	32.5	23	22		1.35		1.5
24	22.2		1.2		3.1	4.2	2	33	24	22.9	0	1.35		1.7
25	23.2	±0.2	1.2	±0.06	3.1	4.3	2	34	25	23.9	-0.21	1.35		1.7
26	24.2		1.2		3.1	4.4	2	35	26	24.9		1.35	+0.14	1.7
※27	25		1.2		3.3	4.5	2	36	27	25.8		1.35	0	1.8
28	25.9		1.5		3.1	4.6	2	38	28	26.6		1.65		2.1
29	26.9		1.5		3.5	4.7	2	39	29	27.6		1.65		2.1
30	27.9		1.5		3.5	4.8	2	40	30	28.6		1.65		2.1
32	29.6		1.5		3.5	5	2.5	43	32	30.3		1.65		2.6
34	31.5		1.5		4	5.3	2.5	45	34	32.3		1.65		2.6
35	32.2	±0.25	1.5		4	5.4	2.5	46	35	33		1.65		3
※36	33.2		1.75		4	5.4	2.5	47	36	34		1.9		3
※38	35.2		1.75		4.5	5.6	2.5	50	38	36		1.9		3
※40	37		1.75		4.5	5.8	2.5	53	40	38	0	1.9		3
※42	38.5		1.75		4.5	6.2	2.5	55	42	39.5	-0.25	1.9		3.8
※45	41.5		1.75		4.8	6.3	2.5	58	45	42.5		1.9		3.8
※47	43.4	±0.4	1.75	±0.07	5	6.6	2.5	61	47	44.5		1.9		3.8
※48	44.5		1.75		4.8	6.5	2.5	62	48	45.5		1.9		3.8
50	45.8		2		5	6.7	2.5	64	50	47		2.2		4.5
52	47.8		2		5	6.8	2.5	66	52	49		2.2		4.5
55	50.8	±0.45	2		5	7	2.5	70	55	52	0	2.2		4.5
56	51.8		2		5	7	2.5	71	56	53	-0.3	2.2		4.5

